



DUMPERS

Modelo: 153T-24HP
Diesel

MAYOR
PRODUCTIVIDAD
y eficiencia en
acarreo de materiales

**CARGA
MÁS DE 2.5
TONELADAS**



VENTAJAS PARA TU EMPRESA



Optimizar la
producción



Reduce
accidentes



Ahorro de
tiempo y dinero



Reduce
mano de obra



OFICINA LIMA

Celular : +51 926 755 967
Correo : ventas@comisub.com

SUCURSAL NAZCA

Teléfono : (01) 2545897
Correo : ventas@comisub.com

SUCURSAL AREQUIPA

Celular : +51 990 873 051
Correo : alejandro.goveya@comisub.com

SUCURSAL TRUJILLO

Celular : +51 992 875 801
Correo : vicente.malave@comisub.com

EQUIPAMIENTO

Luces delanteras, luces traseras pirata, luces direccionales y claxon.

CARGA
MÁS DE 2
TONELADAS

TAMAÑO DEL MINI DUMPER DIESEL

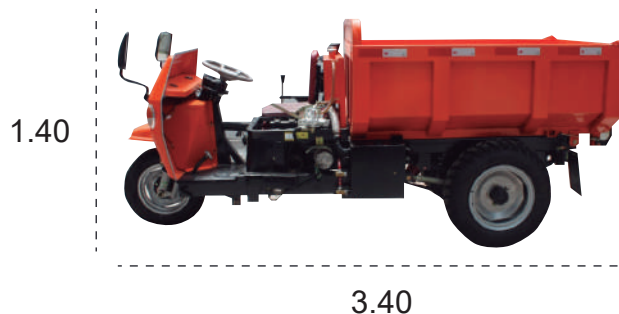
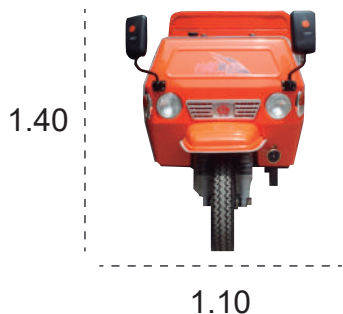

Características principales



Motor: ZS115



24 HP



Catalizador de
emisión de gases



Rendimiento
0.25 gal/hora



Capacidad de carga
2 Toneladas



Diesel



Tolva reforzada:
Ancho: 1.1 m.
Alto: 0.56 m.
Profundidad: 1.80 m.

Especificaciones

Color	Anaranjado
Marca	SL Dumpers
Modelo	153T-24HP
Combustible	Diesel
Carrocería	Acero
Cilindros	1
Capacidad (cm ³)	1,194 cm ³
Potencia Kw (HP)	16.2KW (24HP)
Ruedas	3
Suspensión	Delantera: McPherson Trasera: Muelles
Medida de Neumatico	Delantera: 450 - 14 Trasera: 600 - 16
Distancia entre ejes	2.33 M
LARGO (mm)	3.4M
ANCHO (mm)	1.1M
ALTO (mm)	1.4M
Peso neto	1070KG
Capacidad de Carga	2.5 toneladas
Número de asientos	1
Número de pasajeros	1